



DURMAZ MAKİNA

ÜRÜN KATALOĞU

www.durmazmakina.com



HAKKIMIZDA

1993 yılında ticari faaliyetlerine başlayan Durmaz Makina, marangoz makineleri, palet makineleri, hizar arabası, çoklu kesim ve boylama makineleri gibi endüstriyel makineler konusunda sektörde titizlikle çalışan ve deneyimli bir firmadır.

Durmaz Makina, sektörde 30 yıldan fazla süredir tecrübesiyle müşterilerine kaliteli ve güvenilir makineler sunmaktadır. Marangozluk, palet üretimi, kesim ve hizalama gibi endüstriyel ihtiyaçları karşılayan geniş ürün yelpazesi ve deneyimli kadrosuyla sektörde öne çıkmaktadır.

Firmamız, müşteri talepleri doğrultusunda istenilen özelliklere ve ölçülere uygun olarak özelleştirilmiş makineler üretmektedir. Her müşterinin ihtiyaçları farklı olduğundan, esnek üretim süreçleriyle müşterilerimizin beklentilerini en iyi şekilde karşılamayı hedefliyoruz.

Durmaz Makina olarak, müşteri memnuniyetini en üst seviyede tutmayı ilke edinmiş bir firmayız. Yüksek kaliteli malzemelerden üretilen ve titiz bir üretim sürecinden geçen makinelerimiz, uzun ömürlü kullanım ve güvenilirlik sunar.

Durmaz Makina, sektördeki öncü konumunu koruyarak müşteri odaklı çalışma prensibiyle, endüstriyel makinelerinize güvenilir ve kaliteli çözümler sunmaya devam etmektedir.

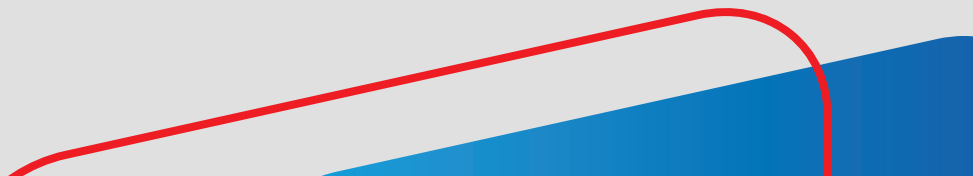

İÇİNDEKİLER

Kısa Tip Full Otomatik Tomruk Kesme Makinası	01
14cm Çoklu Kesim Makinası	02
Tomruk Kesme Makinası	03
Takoz Kesme Makinası	04
Boylama Makinası	05
Yan Alma Makinası	06
Uzun Tip Full Otomatik Tomruk Kesme Makinası	07
Enine Lata Boyutuna Götürücü	08
Lata Boyutuna Götürücü	09
Full Otomatik Boylama Makinası	10



KISA TİP FULL OTOMATİK TOMRUK KESME MAKİNASI

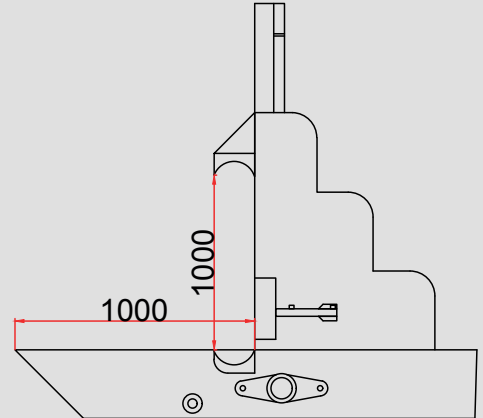
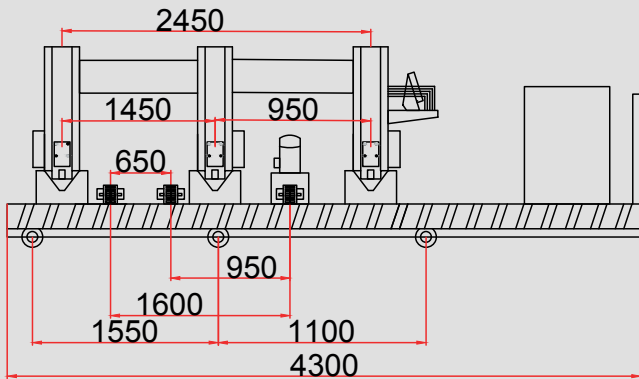

TOMRUK ÇAPI	1200 MM
GÜNLÜK KESİM KAPASİTE /TOMRUK	4500 MM
RAY /YOL UZUNLUK	14000 MM
RAY /GENİŞLİK	13400 MM
KANCA ARASI MESAFE AÇILIMI	1000/2500/3500 MM
ÇİZMELER ARASI MESAFE AÇILIMI (MERKEZ)	1500/3000/4000 MM
DAYAMA KANCA ARASI MESAFE	12 CM
ARABA HAREKET SİSTEMİ	HİDROLİK/12 MM ÇELİK HALAT
ARABA İLERLEME HIZI	1.7 M/SN
ARABA GÜÇ AKTARMA	120 DVR HİDRO MOTOR SİSTEMİ
ÇİZME HIZI	200 MM/SN/SÜRÜCÜ MERKEZLİ
ÇEVİRME SİSTEMİ	2.2 KW/40 DVR REDİKTÖRLÜ MOTOR
ÇEVİRME KALDIRMA SİSTEMİ	HİDROLİK
KANCA GÜÇ AKTARMA	HİDROLİK
HİDROLİK ÜNİTE SİSTEMİ	5.5 KW HİDROLİK POMPA SİSTEMİ
YAĞLAMA SİSTEMİ	MANUEL YAĞLAMA
BOYUTLAR (UZUNLUK,GENİŞLİK,YÜKSEKLİK)	4500/2000/2000 MM
ÖLÇÜ SİSTEMİ	4 İNÇ DOKUNMATİK EKРАН BİLGİSAYAR
MAKİNA GÜÇ AKTARMA	4X2.5 KABLO /10KW/GÜÇ/30 AMP

14 CM ÇOKLU KESİM MAKİNASI



KESME YÜKSEKLİĞİ	140 MM
MİL KULANIM ALANI	480 MM
DAİRE TESTERE MİL MOTORU GÜÇ AKTARMA	55 KW / 3000
DAİRE TESTERE (TEPSİ) ADETİ	6
DAİRE TESTERE GÖBEK MİL CAPI	700 MM
DAİRE TESTERE ÇAPI	400 MM
GENİŞLİK	1060 MM
UZUNLUK	1300 MM
YÜKSEKLİK	1100 MM
MAKİNA AĞIRLIĞI	1100 MM
BESLENME & GÜÇ AKTARIMI	380 VOLT / 60 KW / 50 HZ / KAYIŞ SİSTEMİ
ELEKTRİK KAPASİTE	60 KW

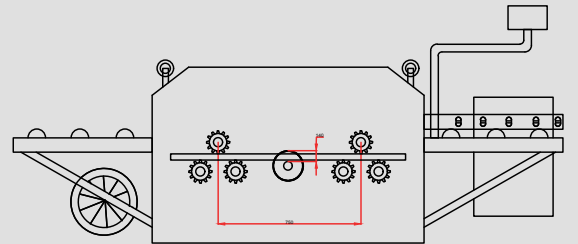
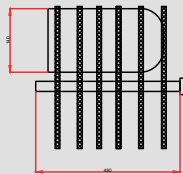
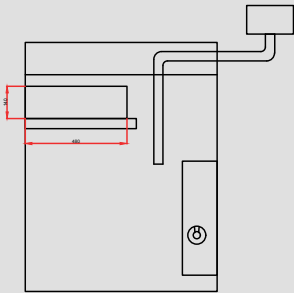
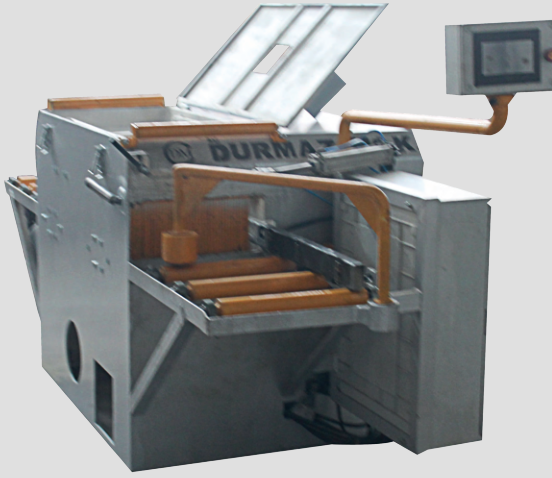

TOMRUK YÜKLEYİCİ (KONVERTİYON) MAKİNASI



YÜKSEKLİK	800 MM
EN	900 / 1300 / 2400 MM
BOYU	4900 MM
MOTORDAN MİLE GÜÇ AKTARMA	ÇİFT SIRA 1/16 ZİNCİR
ORTA MİL ÇAPI	650 MM
AYARLANABİLİR AYAK SİSTEMİ	360 MM METRİK ÇELİK
TOMRUK TAŞIMA SİSTEMİ	360 MM METRİK ÇELİK
ANA GÖVDE	1800 NPI ÇELİK
AYAKLAR VE ARA BAĞLANTI	800 / 1400 NPI ÇELİK
TOMRUK ARABAYA AKTARIMI	800 / 1400 NPI ÇELİK
TOMRUK YÜKLEME HIZI	30 / DK
ANA MOTOR GÜÇ AKTARMA	4 KW 1400 DVR / 30 AMP / 380 VOLT
MAKİNA AĞIRLIK	1000 KG

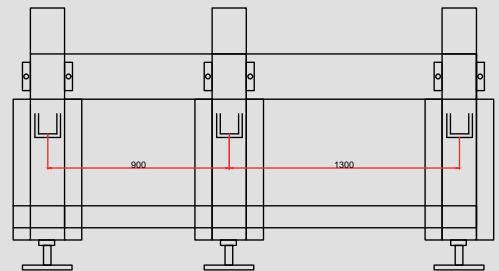
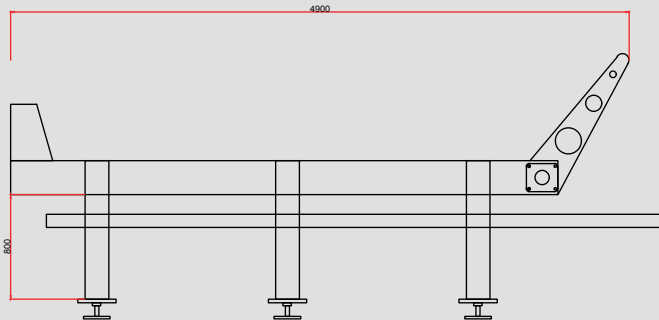

TAKOZ KESME MAKİNASI



TESTERE MOTOR GÜCÜ	4 KW / 3000 DVR / COMPAK TİP
ÇALIŞMA SİSTEMİ VE MOTOR GÜÇ AKTARMA	KAYIŞ
KESME YÜKSEKLİĞİ	125 MM
KESME UZUNLUĞU	150 MM
KESME GENİŞLİĞİ	125 MM
KESME HIZI	DK / 45 ADET
EN / BOY / YÜKSEKLİK	1200/1000/1000 MM
AĞIRLIK	450 KG

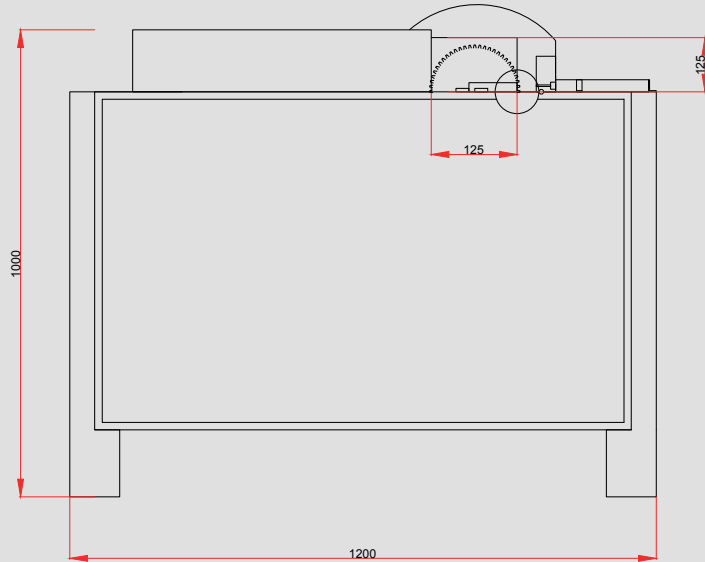

BOYLAMA MAKİNASI



GENİŞLİK/EN/BOY	1100/1100/4400 MM
MOTORDAN DAİRE TESTERE GÜÇ AKTARMA	KAYIŞ
KESİM GERİ ÇEKME	YAY /HAVALI PİSTON
LATA KESİM SİSTEMİ	MAKARNA
LATA ÖLÇÜ SİSTEMİ	4 ÖLÇÜ APARATI/160CM
MOTOR GÜÇ AKTARMA	5.5 KW/3000 DVR/380VOLT/COMPAK TIP
KESME YÜKSEKLİĞİ	150 MM
KESME GENİŞLİĞİ	500 MM
DAİRE TESTERE ÇAPI	4500 MM
DAİRE TESTERE MİL ÇAPI	300 MM
MAKİNA AĞIRLIĞI	300 KG

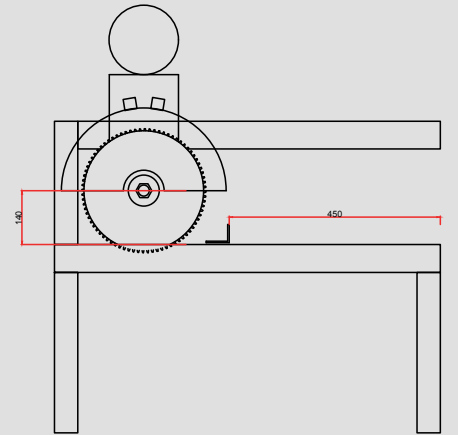
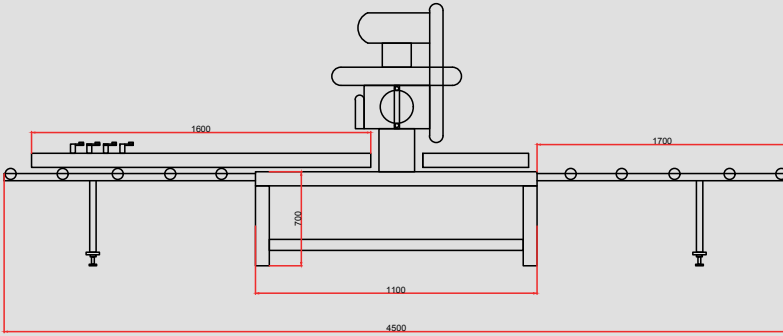

YAN ALMA MAKİNASI



KESME YÜKSEKLİĞİ	500 MM
MİL KULANIM ALANI	700 MM
DAİRE TESTERE MİL MOTORU GÜÇ AKTARMA	13 KW / 3000 DVR
DAİRE TESTERE BAĞLANTI MİL GÖBEK ÇAPI	700 MM
DAİRE TESTERE (TEPSİ) ÇAPI	2500 MM
MAKİNA AĞIRLIĞI	650 KG
GÜÇ AKTARIMI & BESLEME	380 VOLT / 50 HZ / 20KW GÜÇ
MOTORDAN & MİLE GÜÇ AKTARIMI	DİREK MİLE BAĞLI
MERDANELERLE GÜÇ AKTARMA	1/16 TEK SIRA ZİNCİR / KW 60 DVR REDİKTÖR

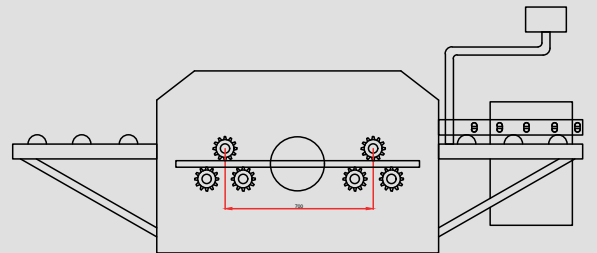
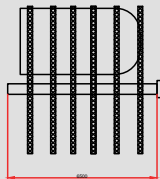
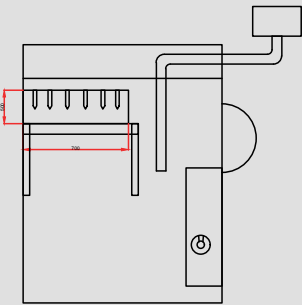

UZUN TIP FULL OTOMATİK TOMRUK KESME MAKİNASI



TOMRUK ÇAPI	1200 MM
GÜNLÜK KESİM KAPASİTE / TOMRUK	4500 MM
RAY /YOL UZUNLUK	14000 MM
RAY /GENİŞLİK	13400 MM
KANCALAR ARASI MESAFE AÇILIMI	1450/2400/3850 MM
ÇİZMELER ARASI MESAFE AÇILIMI (MERKEZ)	1500/3000/4000 MM
DAYAMA KANCA ARASI MESAFE	12 CM
ARABA HAREKET SİSTEMİ	HİDROLİK/12 MM ÇELİK HALAT
ARABA İLERLEME HIZI	1.7 M/SN
ARABA GÜÇ AKTARMA	120 DVR HİDRO MOTOR SİSTEMİ
ÇİZME HIZI	200 MM/SN/SÜRÜCÜ MERKEZLİ
ÇEVİRME SİSTEMİ	2.2 KW/40 DVR REDİKTÖRLÜ MOTOR
ÇEVİRME KALDIRMA SİSTEMİ	HİDROLİK
KANCA GÜÇ AKTARMA	HİDROLİK
HİDROLİK ÜNİTE SİSTEMİ	5.5 KW HİDROLİK POMPA SİSTEMİ
YAĞLAMA SİSTEMİ	MANUEL YAĞLAMA
BOYUTLAR (UZUNLUK,GENİŞLİK,YÜKSEKLİK)	5500/2000/2000 MM
ÖLÇÜ SİSTEMİ	4 İNÇ DOKUNMATİK EKREN BİLGİSAYAR
MAKİNA GÜÇ AKTARMA	4X2.5 KABLO /10KW/GÜÇ/30 AMP

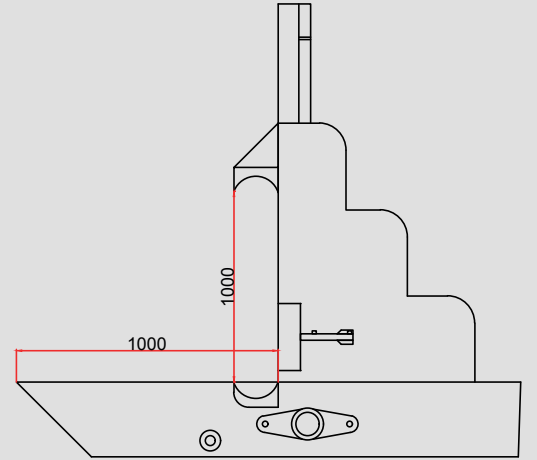
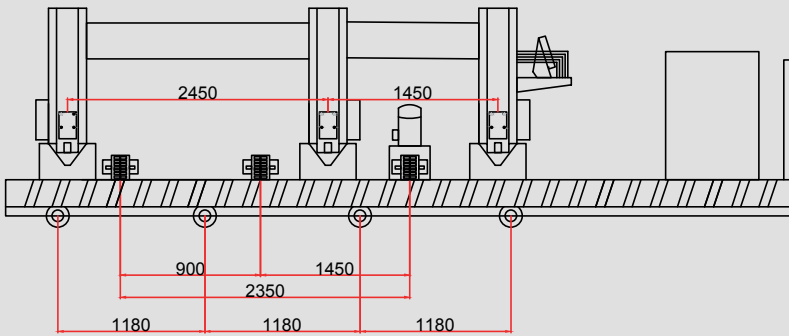

ENİNE LATA BOYUTUNA GÖTÜRÜCÜ



LATA TAŞIMA SİSTEMİ	4X15 ASKER ÇELİK /1/16 TEK SIRA ZİNCİR
İLERLEME HIZI	50M./DK
ANA REDİKTOR	3 KW /40 DVR
LATA TAŞMA GÜÇ HAREKET SİSTEMİ	400 MM
ANA GÖVDE	100 NPI ÇELİK
ANA ŞASE	1200 NPI ÇELİK
AYARLANABİLİR AYAK SİSTEMİ	60X60X3 MM PROFİL/ 24 METRİK
MAKİNA AĞIRLIĞI	350 KG
EN / BOY / YÜKSEKLİK	2400/2300/950 MM
TAŞIMA ARASI	800/800/800/800 MM

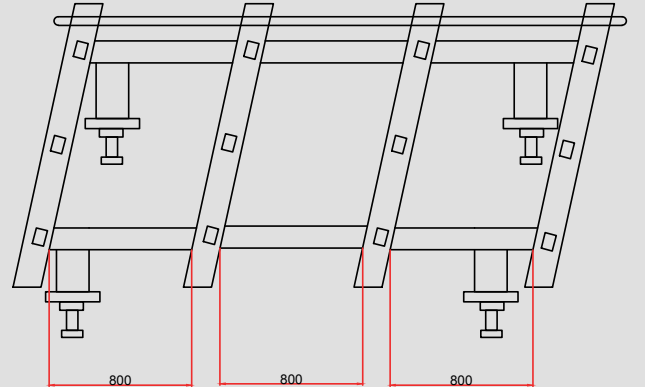
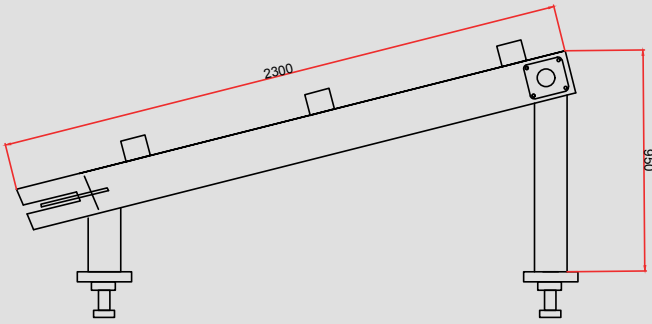

LATA BOYUTUNA GÖTÜRÜCÜ



SİSTEM HAREKETİ	1 / 16 TEK SIRA ZİNCİR
GÜÇ AKTARMA	380 VOLT / 3 KW 1400 DVR / 50 HZ
ÇALIŞTIRMA TAHRİK	1 / 16 TEK SIRA ZİNCİR 400 MM ÇELİK MİL
GÖTÜRME HIZI	0-45 M / DK
ANA MOTOR	3 KW / 60 DVR
HAREKETİ	1 / 16 ZİNCİR
BORU ÇAPI	1680 MM ÇAP / 30 MM
SARGILAR	250 MM KÖŞEBENT
ANA ŞASE & AYAKLAR	100 NPU ÇELİK / 60x60 3MM PROFİL
EN / BOY / YÜKSEKLİK	750 MM / 6000 / 11/16 DİŞLİ
MAKİNA AĞIRLIĞI	500 KG

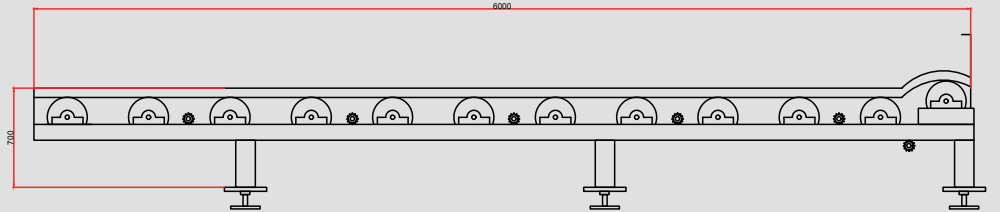
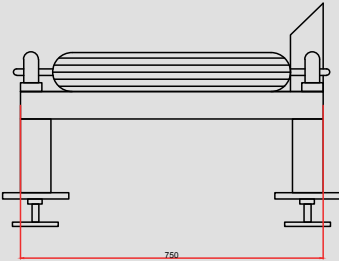

FULL OTOMATİK BOYLAMA MAKİNASI





DURMAZ MAKİNA

www.durmazmakina.com

+90 537 336 76 98
+90 538 769 46 03

bilgi@durmazmakina.com

Fevzi akmak mah. Esenler cad. No:18
Büsan Özel Organize Sanayi Bölgesi **Karatay/ KONYA**